

CASE 1 : ELEVATED HIGHWAY STRUCTURE WITH ADJACENT AT-GRADE ROAD

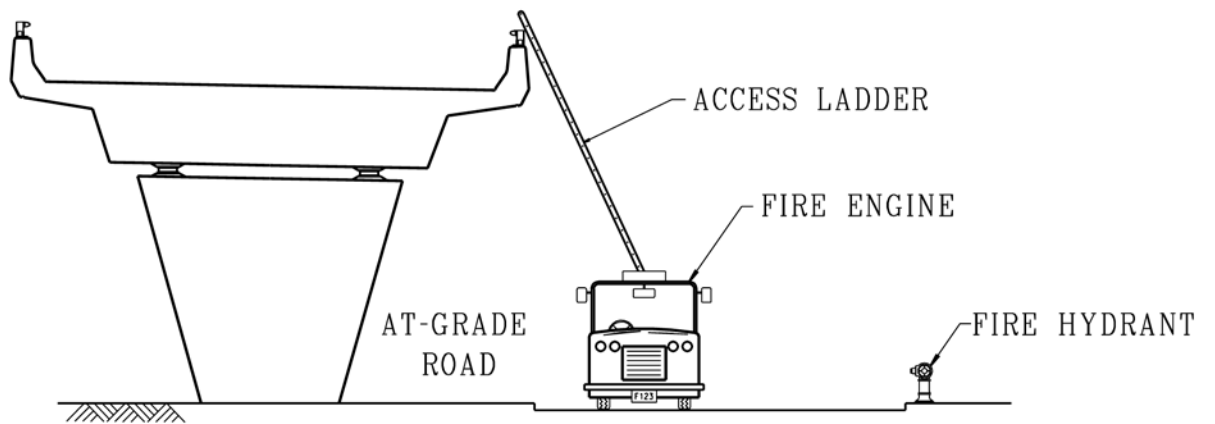

FIG. 1

CASE 2 : SHORT FLYOVER

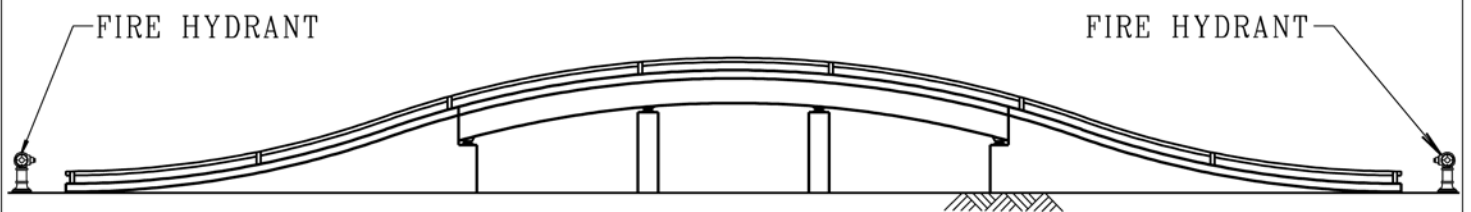

FIG. 2

CASE 3 : LONG VIADUCT

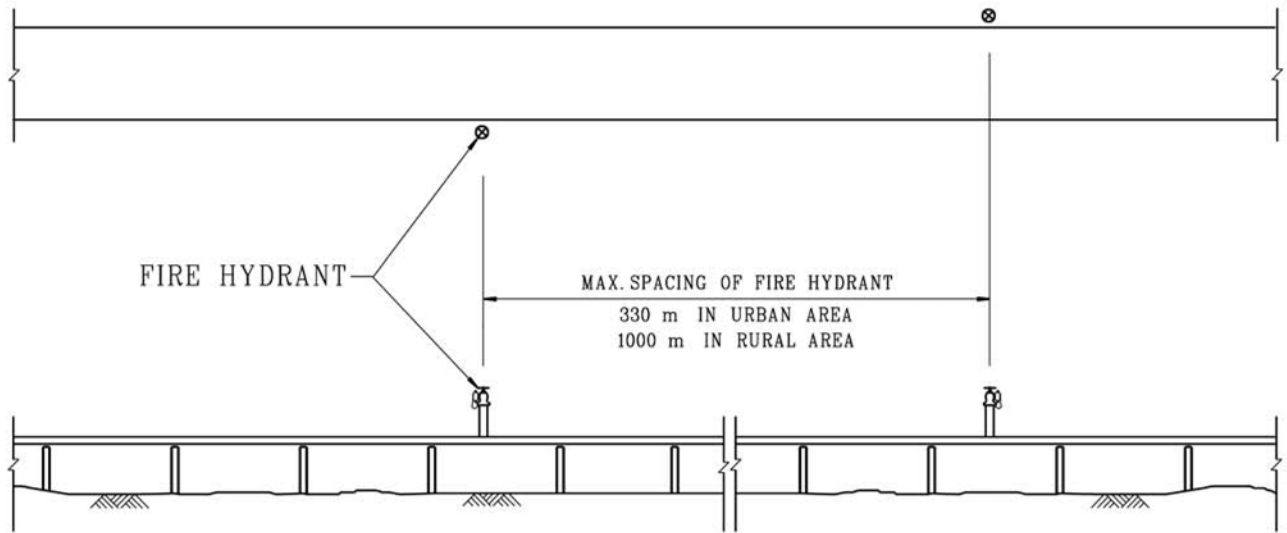
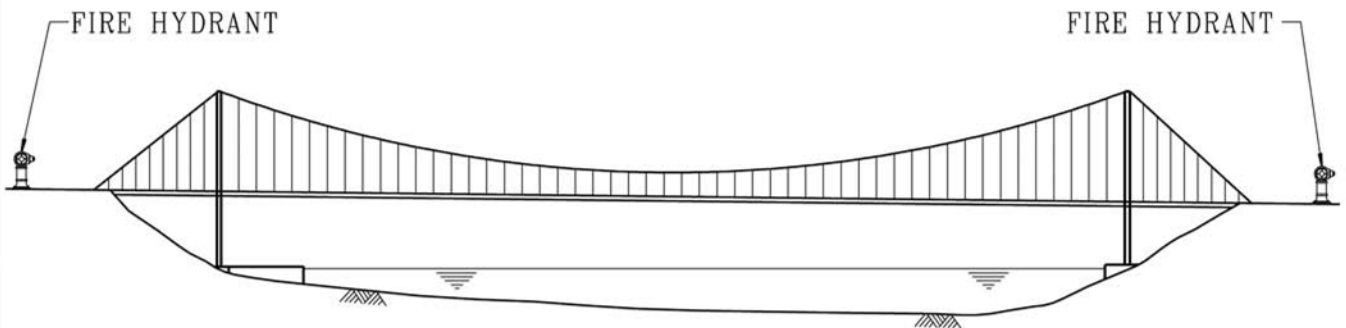

FIG. 3

CASE 4 : LONG SPAN CABLE-SUPPORTED BRIDGE



NOTE: WATER TENDERS SHALL BE PROVIDED TO FSD REQUIREMENTS

FIG. 4

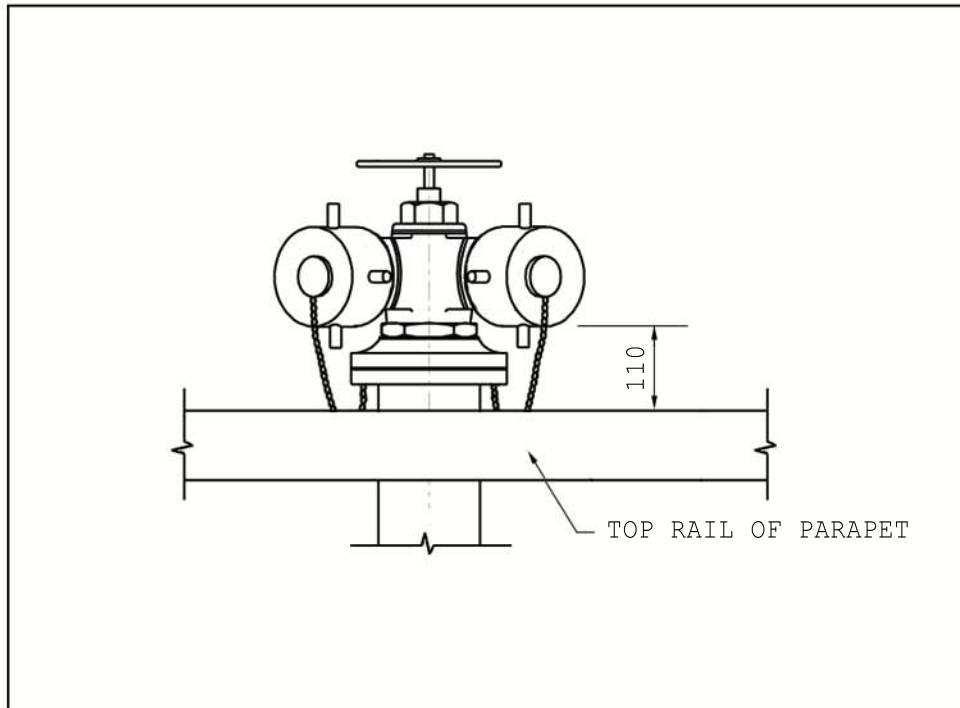

FIG.5 - RAISING OF FIRE HYDRANT ON
ELEVATED HIGHWAY STRUCTURES
TO AVOID OBSTRUCTION