

BRACKET (TYPE A)

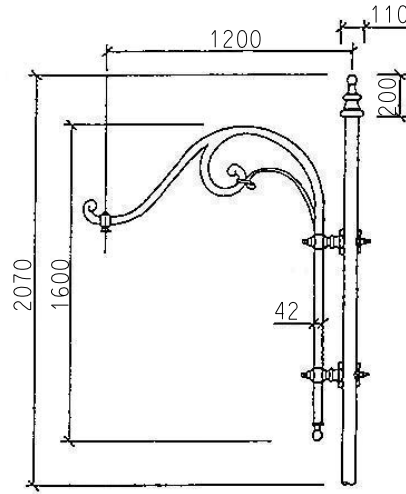

BRACKET (TYPE B)

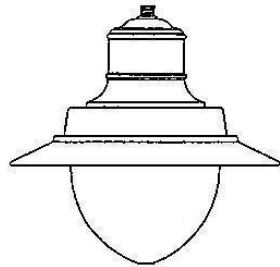

LANTERN

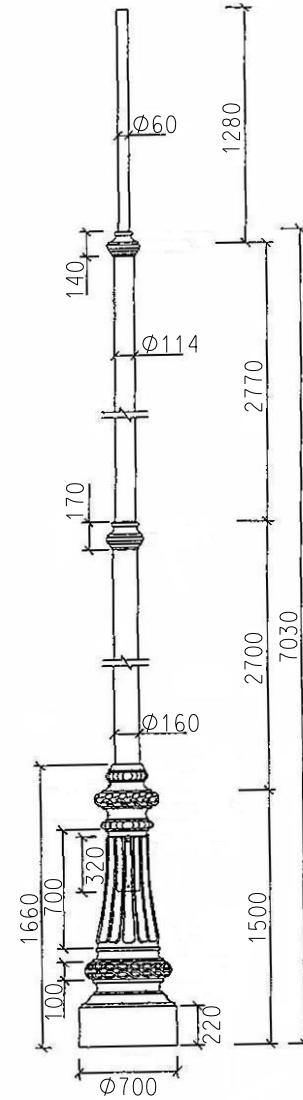

COLUMN

NOTES:

1. ALL PROPOSED LANTERNS, BRACKETS AND COLUMNS SHALL BE SUBMITTED FOR THE ENGINEER'S APPROVAL.
2. ALL DIMENSIONS ARE IN MILLIMETRES.

TYPE D

REF.	REVISION	SIGNATURE	DATE
------	----------	-----------	------

HIGHWAYS DEPARTMENT
LIGHTING DIVISION

REFERENCE	DRAWING No.	CAD
-----------	-------------	-----

SCALE
N. T. S.

HLSDML07-CL1026

DECORATIVE LIGHTING AND COLUMNS IN PENNY'S BAY
(SHEET 3 of 4)