

END VIEW
BACK PLATE

ELEVATION
BACK PLATE

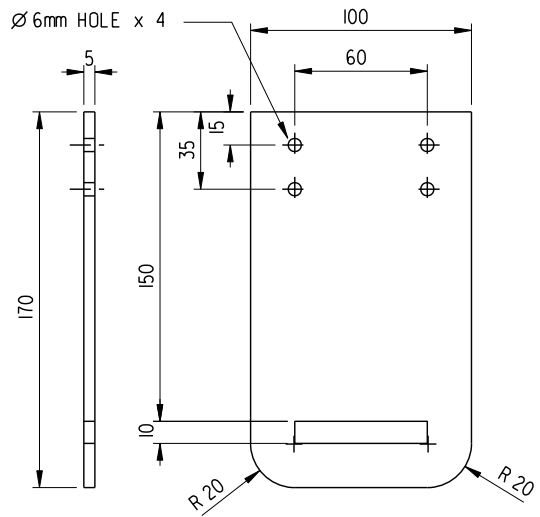

END VIEW
FRONT PLATE

ELEVATION
FRONT PLATE

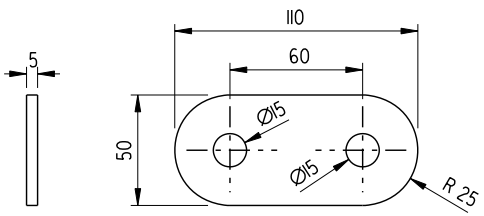

END VIEW

ELEVATION

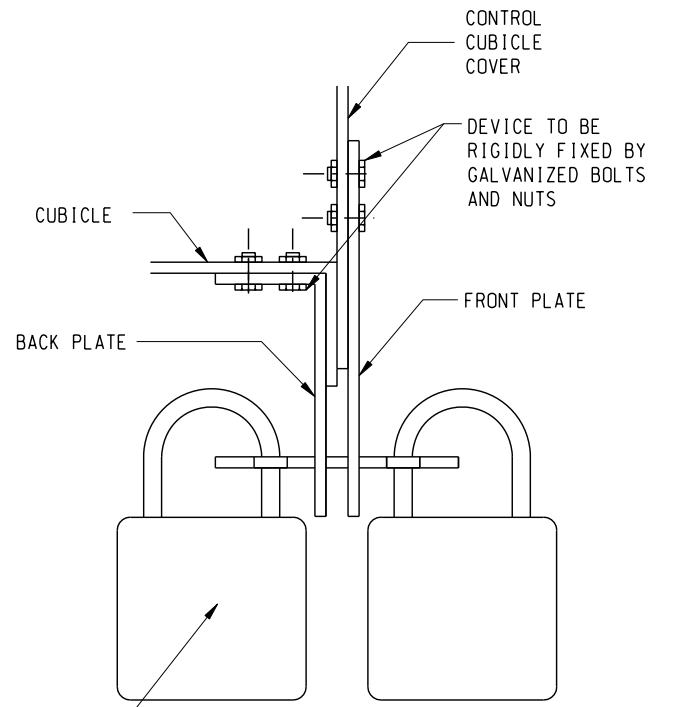

ASSEMBLY SECTIONAL
VIEW

- NOTE:
1. ALL DIMENSIONS ARE IN MILLIMETRES.
 2. BACK PLATE SHALL BE MADE OF HOT DIP GALVANIZED MILD STEEL PLATE.

	Former Drg. No. HLSDGE01-CL0011B with general revision		Feb 06
REF.	REVISION	SIGNATURE	DATE

LOCKING DEVICE FOR FIBRE GLASS CONTROL CUBICLE

HIGHWAYS DEPARTMENT LIGHTING DIVISION		
REFERENCE	DRAWING No.	CAD
SCALE	HLDSDML06-CL1019	
N.T.S.		