

TOP VIEW

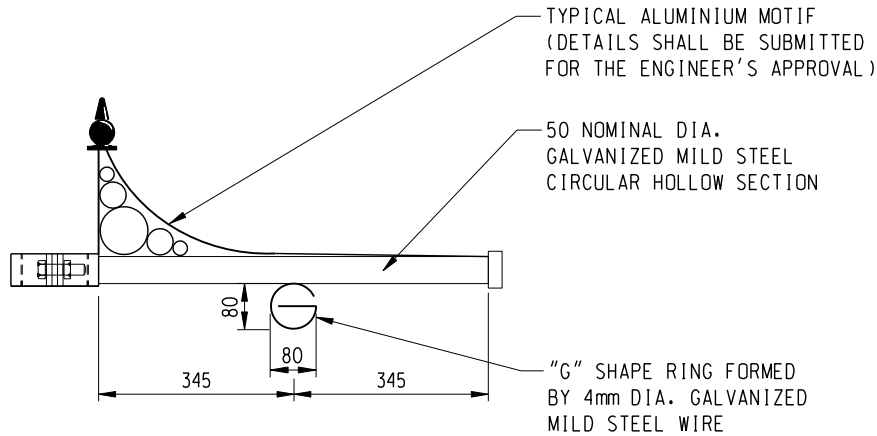

SIDE VIEW

TYPE OF COLUMN	COLLAR 'D' (mm)
4m	82
5.1m	82
8m	120
10m	120
12m	146

NOTES:

1. ALL DIMENSIONS ARE IN MILLIMETERS.
2. END DETAIL TO BE CHOSEN TO SUIT SITE.
3. ALL WELDS TO BE GROUND SMOOTH.
4. STEEL TO BE GRADE 43 BS 4360.
5. ALL STEELWORK SHALL BE HOT DIP GALVANIZED TO BS EN ISO 1461
6. THE ALUMINIUM MOTIF AND "G" SHAPE RING SHALL BE WELDED ONTO THE GALVANIZED MILD STEEL PIPE BY ALL ROUND 4mm FILLET WELD.
7. THE ALUMINIUM MOTIF ANF "G" SHAPE RING SHALL BE INSTALLED AS AND WHEN INSTRUCTED BY THE ENGINEER.

A	General revision		Mar 07
	Merge Drg No. LSDML02-CL0018 & HLSDHK05-CL2022A		Feb 06
REF.	REVISION	SIGNATURE	DATE

SINGLE ARM BANNER BRACKET

HIGHWAYS DEPARTMENT  
LIGHTING DIVISION

REFERENCE	DRAWING No.	CAD
SCALE	HLSDGE06-CL0042A	
N.T.S.		