

TYPE A BRACKET

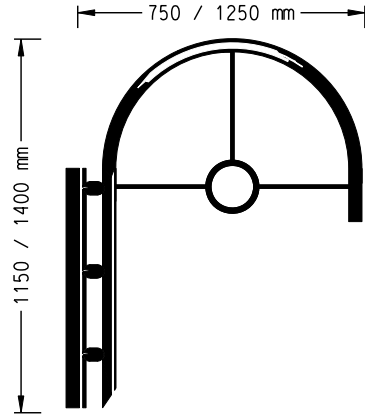

TYPE B BRACKET

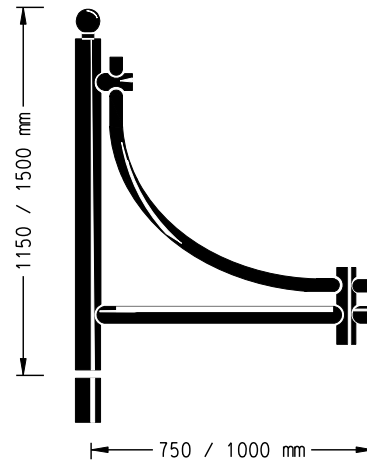

TYPE C BRACKET

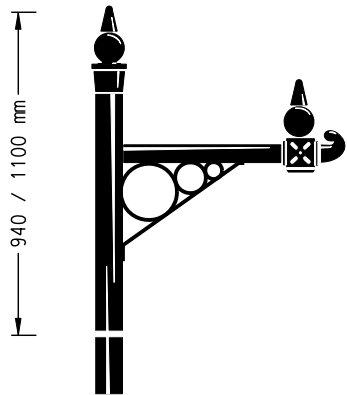

TYPE D BRACKET

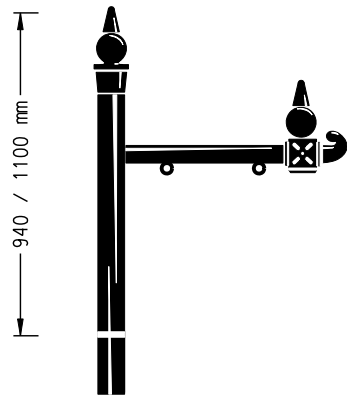

TYPE E BRACKET

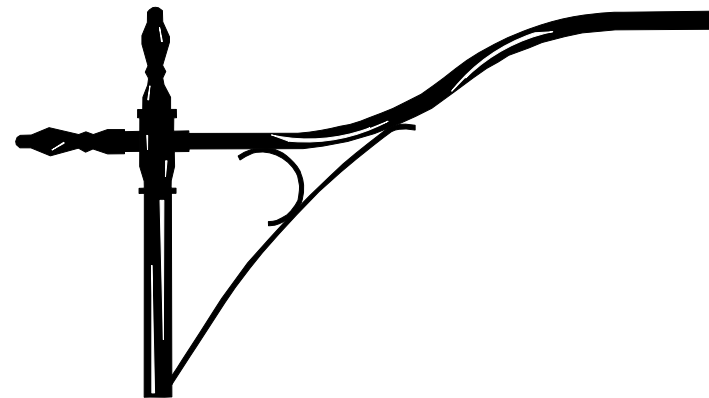

TYPE F BRACKET

NOTE:

1. THE SMALLER DIMENSION IS FOR COLUMN HEIGHT OF 5.1M.
2. THE LARGER DIMENSION IS FOR COLUMN HEIGHT OF 5M OR ABOVE.
3. THE BRACKETS SHOWN ON THIS DRAWING ARE FOR SINGLE-ARM COLUMN LIGHTS. BRACKETS FOR DOUBLE-ARM COLUMN LIGHTS SHALL BE OF SIMILAR SHAPE BUT WITH ADDITIONAL BRACKET ONLY.
4. ALL PROPOSED COLUMN BRACKETS AND EMBELLISHMENT KITS FOR DECORATIVE LANTERNS SHALL BE SUBMITTED FOR THE ENGINEER'S APPROVAL. MINOR AMENDMENTS TO THE BRACKETS MIGHT BE PROPOSED BY THE ENGINEER TO SUIT THE ACTUAL SITE CONDITION.

C	Brackets Added with Notes Revised		May 07
B	Former drawing NO.LDSDGE01-CL0029A		Jul 02
A	General revision		Jun 02
REF.	REVISION	SIGNATURE	DATE

TYPICAL COLUMN BRACKETS
AND EMBELLISHMENT KITS FOR
DECORATIVE LANTERNS (SHEET 2 OF 4)

HIGHWAYS DEPARTMENT
LIGHTING DIVISION

REFERENCE	DRAWING No.	CAD
SCALE	HLSDGE01-CL0030C	
N.T.S.		