

NOTES:

1. ALL DIMENSIONS ARE IN MILLIMETERS.
2. THE BRACKET PROJECTION LENGTH AND THE TILTING ANGLE OF LANTERN SHALL BE SPECIFIED BY THE ENGINEER.
3. STEEL GRADE OF AT LEAST Q345 COMPLYING WITH GB/T700 SHALL BE USED FOR THE BRACKET. ALL STEEL SHALL BE APPLIED WITH TREATMENT SAME AS THE S-TYPE PUBLIC LIGHTING COLUMN SPECIFIED IN DRAWING NO. HLSDGE07 - CL0049. THE COLOUR OF BRACKET SHALL BE SPECIFIED BY THE ENGINEER.
4. FOR NON-SPECIFIED DIMENSIONS, RELEVANT APPROVAL BY THE ENGINEER SHALL BE SOUGHT.

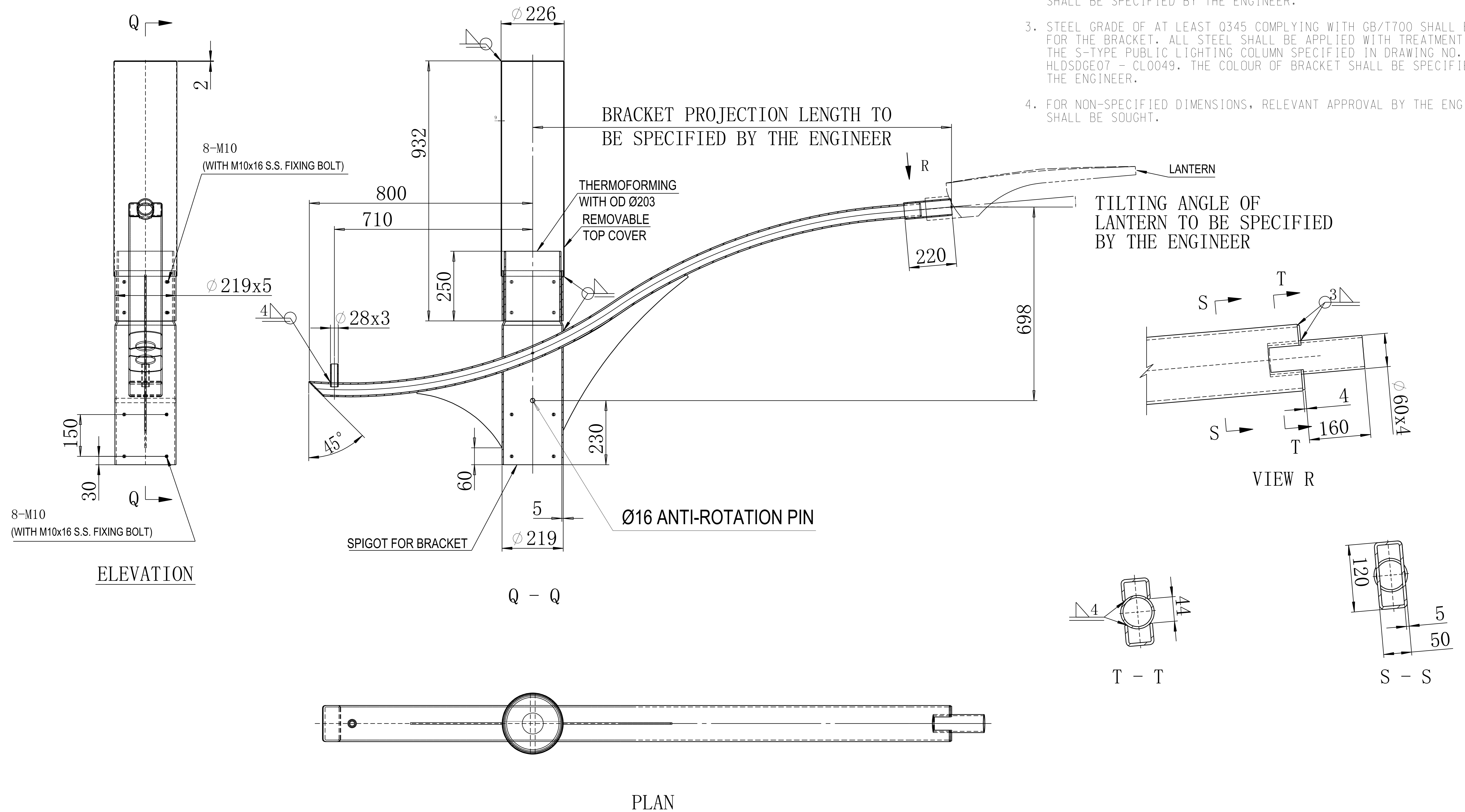

	New issue		Mar 20
REF.	REVISION	SIGNATURE	DATE
HIGHWAYS DEPARTMENT LIGHTING DIVISION			
REFERENCE	DRAWING No.	CAD	
SCALE	N.T.S.	HLSDGE07-CL0052	

DETAILS OF TYPE SL BRACKET FOR PUBLIC LIGHTING COLUMN