

**DETAIL 'C'**  
SCALE 1 : 5

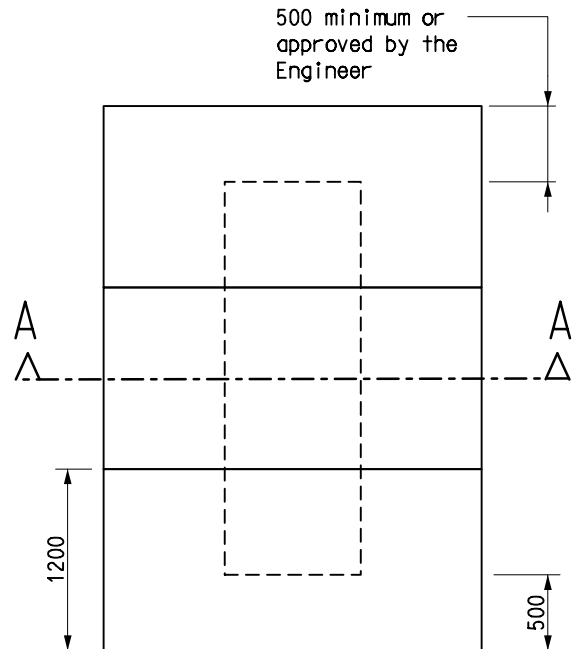

**PLAN**

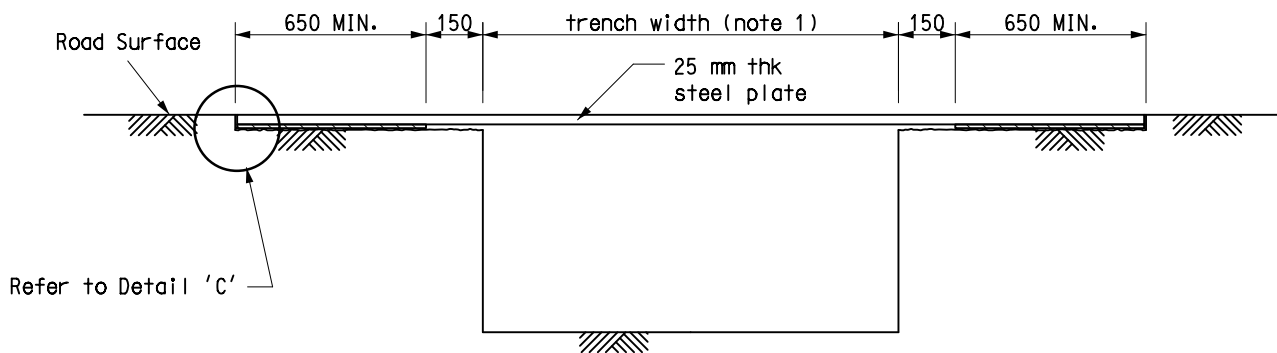

**SECTION A-A**

**Notes :**

1. For trench width of 900mm or more, steel channel details at underside of steel plate as shown in drawing no. H6136/2 shall be adopted.
2. Structural steelwork shall be of grade S275J0 complied with BS EN 10025 or equivalent.
3. Top of steelplate to be treated with anti-skid dressing; other surfaces to be treated with protective painting.
4. Details of lifting holes are to be approved by the Engineer.
5. The surface of the steel plate shall be marked with alternate black and yellow diagonal strips of 300mm width. The yellow markings shall have resistance and reflective characteristics equivalent to common thermoplastic road markings.
6. Alternative design for particular site conditions (e.g. block pavement) shall be approved by chartered engineer and the appropriate authorities shall be notified without undue delay.
7. The name of the roadwork undertaker should be marked on the steel plate for easy identification.
8. Shoring support and drainage measures shall comply with the "Guide to Trench Excavations (Shoring Support and Drainage Measures)".
9. Design to be according to BS EN 1990, 1991, 1993 or other relevant BS EN standard(s).
10. Design of support to the vertical faces of trench shall take into account the loading induced by the decking and the traffic above.
11. For decking with multiple steel plates, the plates should be securely fixed together to prevent dislocation.
12. Gaps between steel plate and adjacent pavement surface and gaps between adjoining steel plates should not be more than 5mm.
13. Surface of the steel plates should not be higher than, and should not be more than 3mm lower than, the surface of the adjacent pavement / steel plates.

A	Note 2 and 9 revised	Original signed	Dec 22
	Former Drg. No. H6162 with note 1 amended and notes 11 to 13 added	-	Nov 13
REF.	REVISION	SIGNATURE	DATE

**TYPICAL VEHICLE CROSSING  
OVER TRENCH OPENING  
FOR RIGID PAVEMENT  
(FLUSH WITH ROAD SURFACE)**

**HIGHWAYS DEPARTMENT**

REFERENCE	RD / 050 A	DRAWING No.	CAD
SCALE	1 : 20 OR AS SHOWN	<b>H 6136/1A</b>	