

SECTION E-E
SCALE 1:5

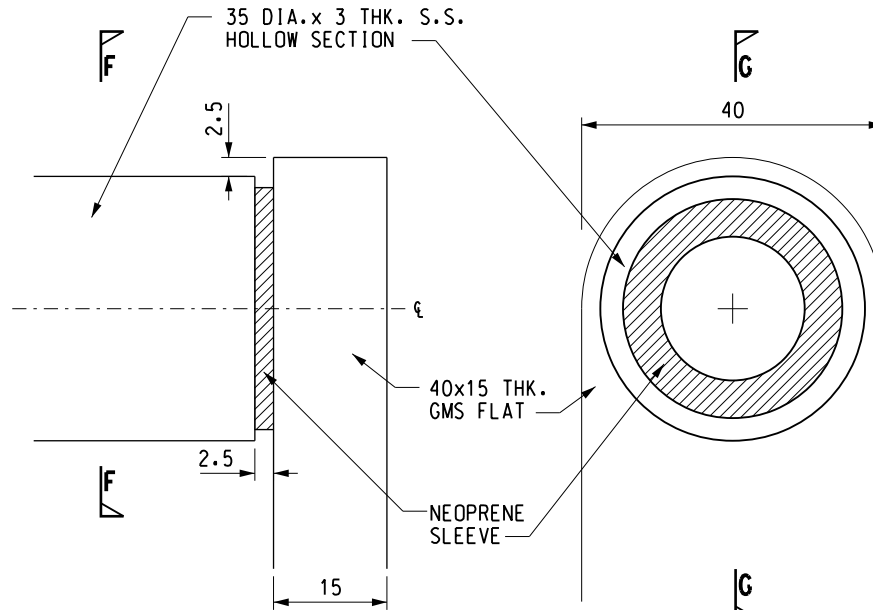

DETAIL 'Z'

SECTION F-F

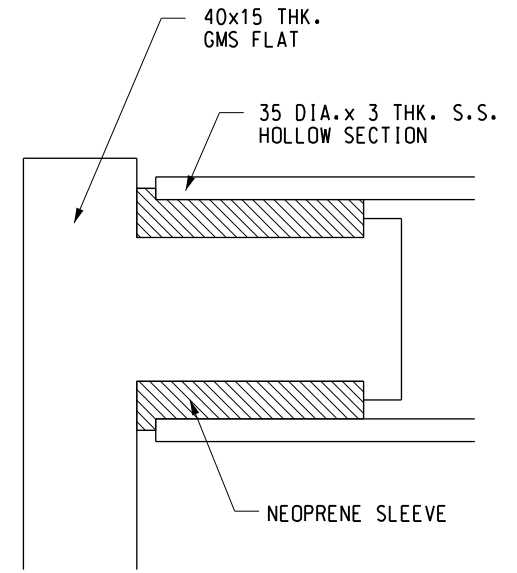

SECTION G-G

NOTE:

1. ALL DIMENSIONS ARE IN MILLIMETRES UNLESS STATED OTHERWISE.
2. THIS DRAWING SHALL BE READ IN CONJUNCTION WITH DRG. NO. H2298.

	New Issue	Original signed	Apr 18
REF.	REVISION	SIGNATURE	DATE

TYPICAL DETAILS FOR TYPE 12 RAILING &
13 RAILING (HIGH VISIBILITY PANEL)
SHEET 2 OF 2

HIGHWAYS DEPARTMENT		
REFERENCE	DRAWING No.	CAD
SCALE 1 : 1 OR AS SHOWN	H 2299	