

### FRONT ELEVATION (VIEW 'X')

(typical of two or more traffic signs in a direction - perpendicular to kerb in this case)

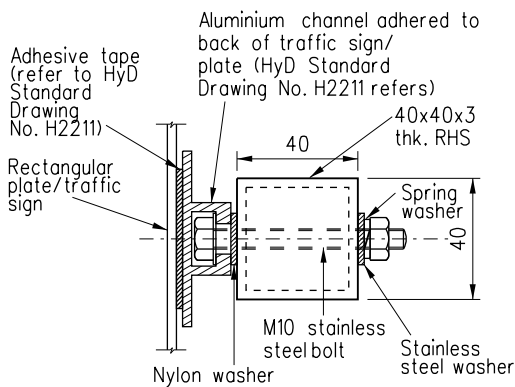

### SECTION B - B

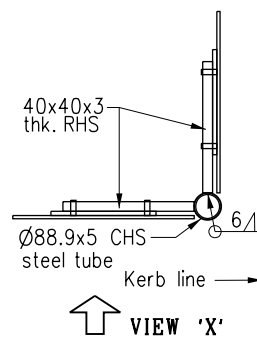

### SECTION A-A

(position between road junctions)

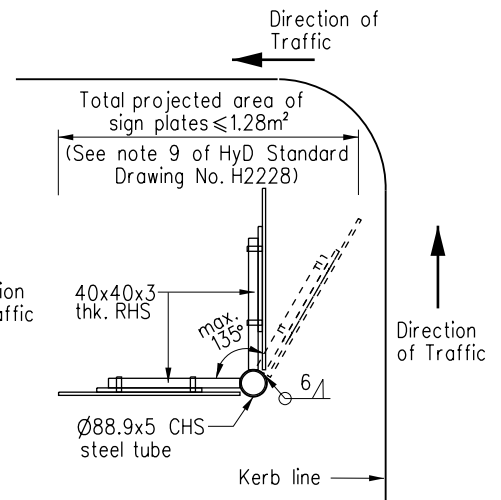

### SECTION A-A

(position at road junction)

#### Notes:

1. Refer to notes 1 to 12 of HyD Standard Drawing No. H2228.
2. Refer to notes 2 to 9 of HyD Standard Drawing No. H2230.
3. The mounting height of traffic sign shall refer to TPDM Vol.3 Clause 2.2.3.1.
4. The 40 solid square steel bar shall be placed freely on the mild steel base plate inside the steel tube.

REF.	REVISION	SIGNATURE	DATE
B	Detachable dome shape cap added and other general revisions	Original signed	Feb 19
A	40 solid square post added.	-	May 18
	New Issue	-	Nov 04

## SINGLE POST MULTI-SIGN SUPPORT FOR CANTILEVER-MOUNTED TRAFFIC SIGNS

## HIGHWAYS DEPARTMENT

REFERENCE

DRAWING No.

CAD

SCALE

NOT TO SCALE

H 2227B