

TYPICAL CONNECTION OF SIGN FACE PANEL
TO SUPPORTING POLES

Scale 1:10

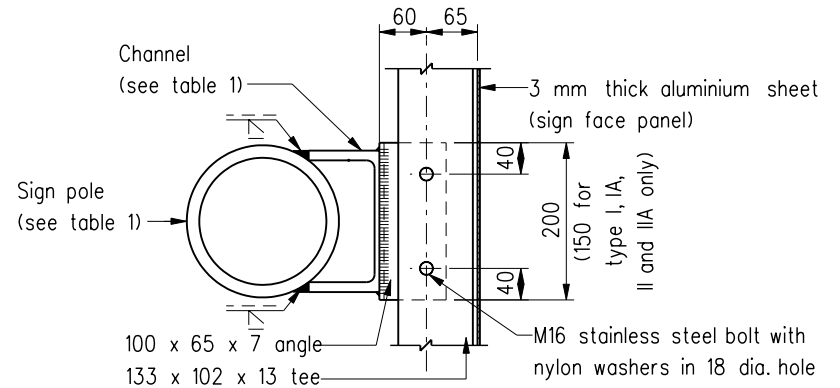

SECTION B-B

Scale 1:10

6 dia. cup-head stainless steel bolt, head painted to match sign face, bolts to be spaced at regular pitch (225 max.) around face panels

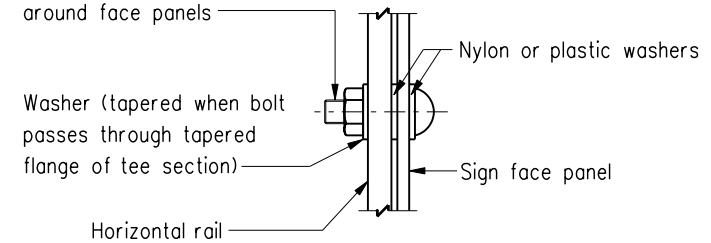

DETAIL 4

Scale 1:2

	New issue		Aug 03
REF.	REVISION	SIGNATURE	DATE

HIGHWAYS DEPARTMENT

REFERENCE	DRAWING No.	CAD
SCALE	H 2214	
As shown		

ROADSIDE DIRECTIONAL SIGNS
(SHEET 3 OF 14)