

TYPICAL TRENCH SECTION

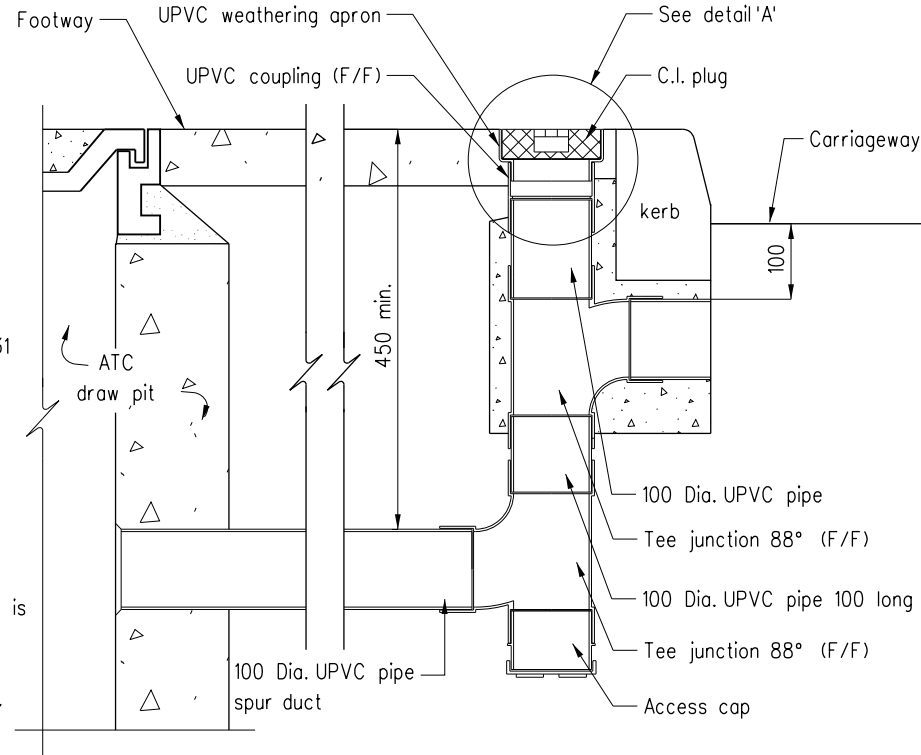

SECTION W - W
(For cable connecting detector loops on c/w)

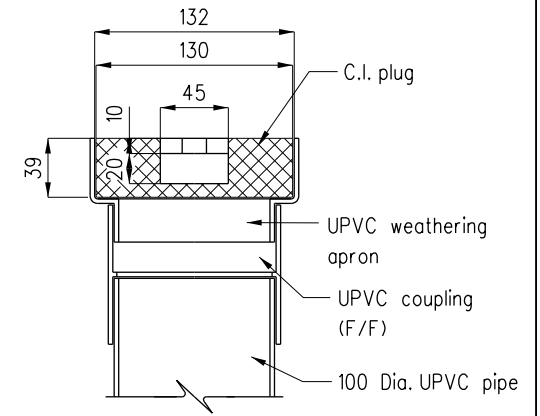

SECTIONAL VIEW

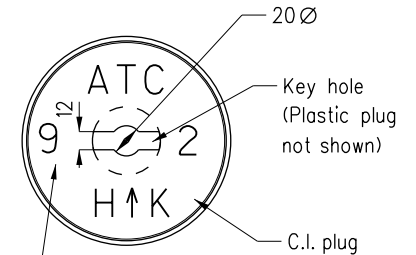

PLAN
DETAIL 'A'

Note :

1. See H2157 for general arrangement and notes

A	Note 1 updated and plastic plug specified	Original signed	May 16
	Former Drg. No. H2036/2 & H2036/3A with general revision	-	June 94
REF.	REVISION	SIGNATURE	DATE

ATC DRAW PIT - DETAILS OF SPUR DUCT

HIGHWAYS DEPARTMENT

REFERENCE	Drg. No. ATC/HK/60	DRAWING No.	CAD
SCALE	Diagrammatic	H 2158A	