

PLAN

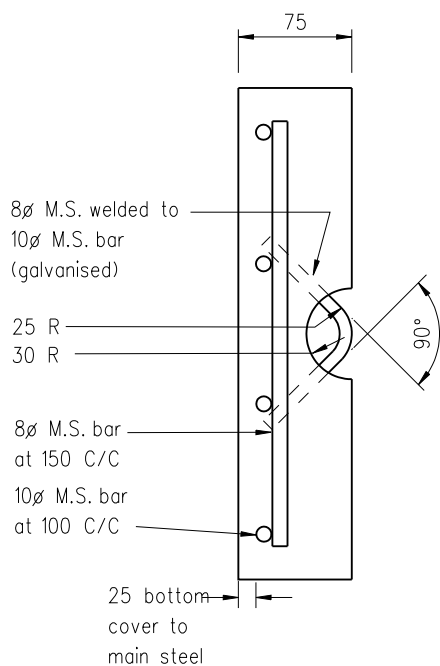

SECTION A - A

PRECAST CONCRETE COVER

Notes:

1. All dimensions are in millimetres.
2. Longitudinal location of emergency telephones to be determined by CE/TCS.
3. Dimensions of draw-pits may vary according to site conditions as agreed with CE/TCS & DEMS..
4. In the absence of safety fences, the telephones posts shall be mounted on far side of the verge away from the carriageway, yet unobstructed by any obstacles, vegetation or standing water.
5. For dimensions of verges, marginal strips and position of safety fences, please refer to Diag. 3.4.12.1 and 3.4.12.2. of TPDM volume 2 chapter 3.
6. If the depth of the draw-pit exceeds 1000, step-iron should be provided and the size should be increased to 900 x 900 (internal dimension) with R.C. cover strips each not exceeding 40 kg.
7. Lettering on the cover shall be produced by engraving on the cover with a preformed mould after initial set of the concrete. The engraved letters shall be neat and tidy. Hand writing is not acceptable. Unless otherwise approved by the Engineer, each letter shall have width in the range of 55mm to 70mm, height in the range of 80mm to 100mm, font style to be "Arial or Times New Roman".

A	Note 7 added		Oct 13
	Former Drg. No. H2035/2 with general revision		June 94
REF.	REVISION	SIGNATURE	DATE

EMERGENCY TELEPHONE  
MOUNTING DETAILS  
- ROADSIDE  
(SHEET 2 OF 2)

HIGHWAYS DEPARTMENT

REFERENCE ATC 262	DRAWING No. H 2151A	CAD
SCALE 1:5		