

COMBINED AMENITY / TRIP RAIL

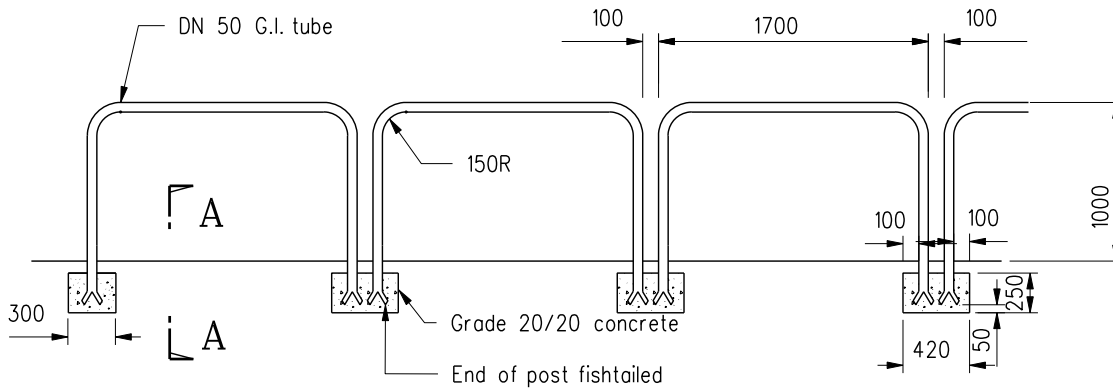

CLOSE SPACED AMENITY RAIL

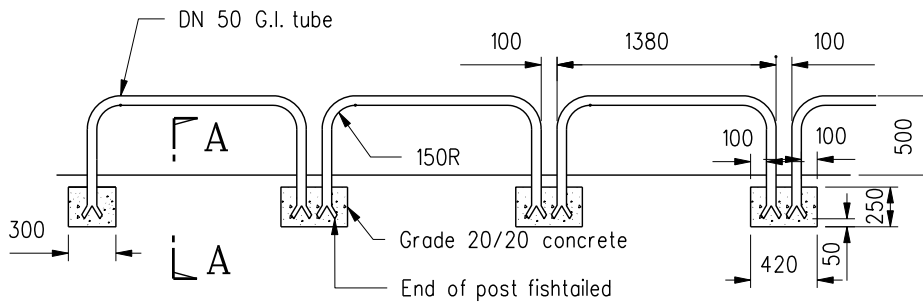

CLOSE SPACED TRIP RAIL

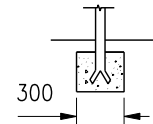

SECTION A - A

Notes:

1. All railing shall be hot dip galvanised to BS EN ISO 1461 : 1999.
2. All dimensions are in millimetres.
3. Where the concrete footing is located in block paved footpath, the footing should be lowered to allow for the paving blocks and the sand course.

B	Note 1 updated		Sep 07
A	Note 3 added		Nov 99
	Former Drg. No. H2025/A with general revision		Jun 94
REF.	REVISION	SIGNATURE	DATE

TYPICAL RAILING
COMBINATIONS

HIGHWAYS DEPARTMENT

REFERENCE

DRAWING No.

CAD

SCALE

1 : 50

H 2138B