

CROSS SECTION OF BEAM

(Scale 1 : 2)

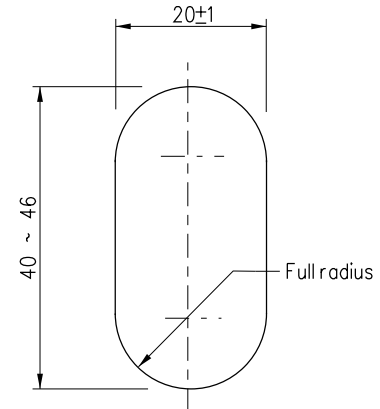

VIEW 'A'

(Scale 1 : 1)

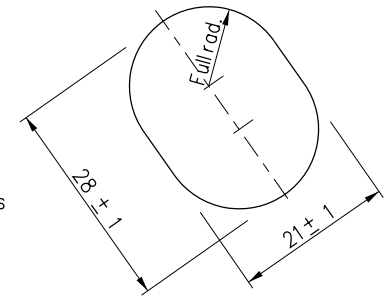

VIEW 'B'

(4 positions)
(Scale 1:1)

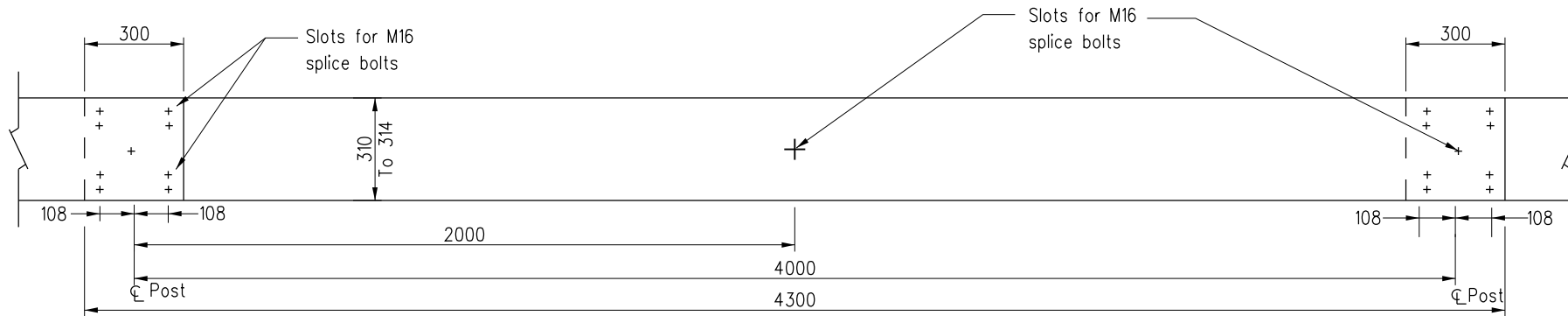

ELEVATION OF BEAM

(Scale 1 : 20)

Notes:

1. Dimensions are in millimetres.
2. The section shall be hot dip galvanized to BS EN ISO 1461 : 1999.

B	Dimension of cross section of beam updated	Original signed	Oct 14
A	Note 2 updated	—	Sep 07
	Former Drg. No. H2005/2 with general revision	—	Jun 94
REF.	REVISION	SIGNATURE	DATE

**BEAM BARRIERS -
CORRUGATED BEAM**

HIGHWAYS DEPARTMENT

REFERENCE

DRAWING No.

CAD

SCALE

As shown

H 2112B