

SECTION C - C

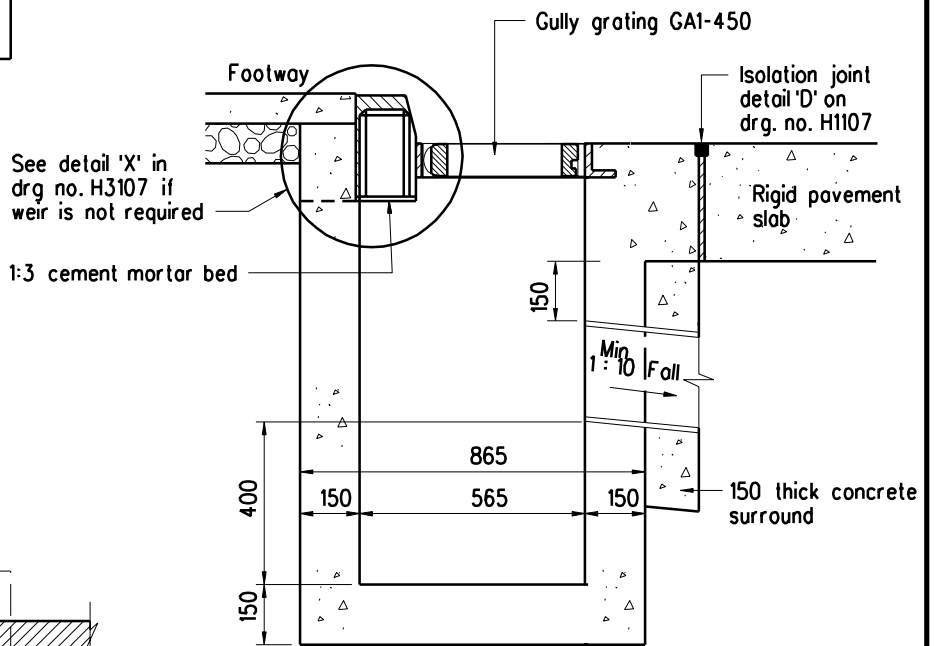

SECTION D - D

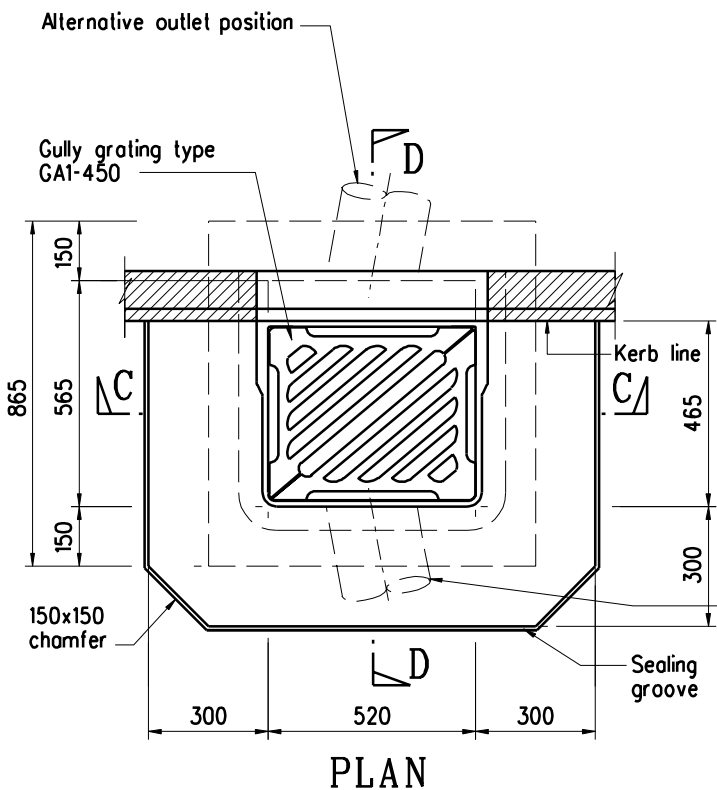

225 dia. pipe to be connected directly to S.W.D. by 'Y' junction or saddle

Note :  
See drg. no. H3107.

Former Drg. No. H3004/2 with general revision		June 94	
REF.	REVISION	SIGNATURE	DATE

UNTRAPPED IN-SITU GULLY  
FOR TYPE GA1-450 GRATING -  
RIGID PAVEMENT

HIGHWAYS DEPARTMENT

REFERENCE	H.O. 7/1/6	DRAWING No.	CAD
SCALE	1 : 20	H 3108	