

FRONT ELEVATION

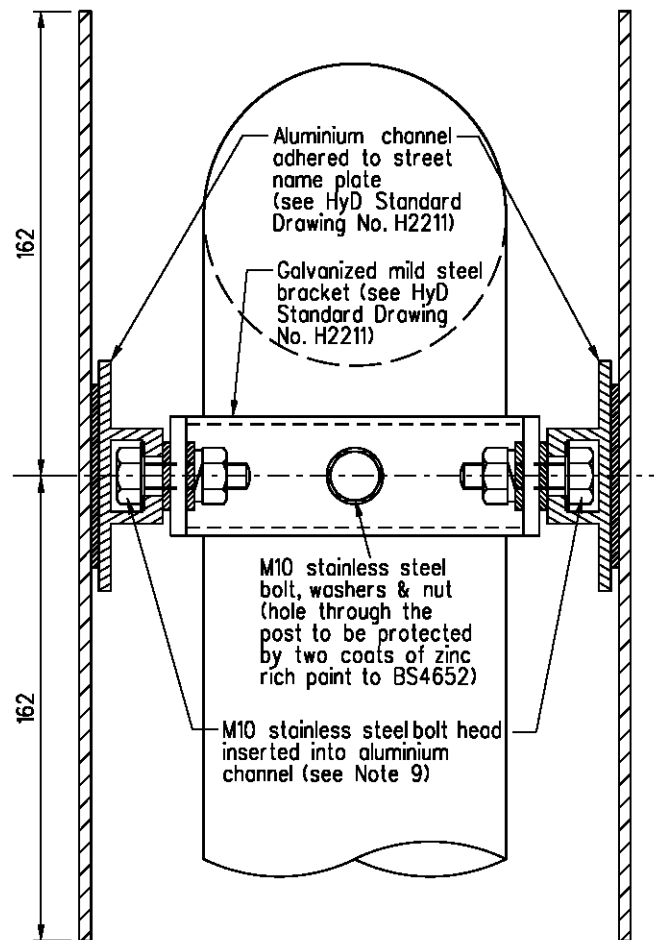

SECTION A-A

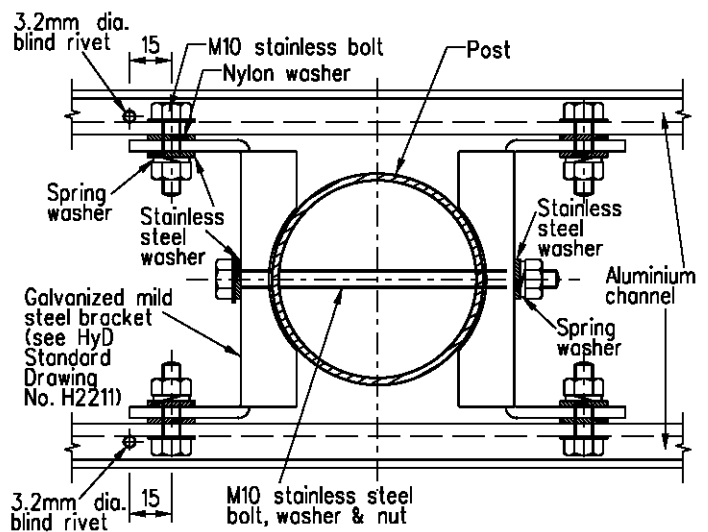

SECTION B-B

Note :

1. All dimensions are in millimetres.
2. Stainless steel shall be Grade 316 to BS1449 Part 2.
3. Spring washer shall be to BS ISO 464:1995.
4. All steelwork (except stainless steel) shall be Grade 43 to BS 4360.
5. All steelwork (except stainless steel) shall be hot dip galvanized to BS EN ISO 1461 : 1999.

Length of Street Name Plate (L)	Post-to-Post Centre Clearance	Length of Aluminium Channel required
≤ 1400mm	≤ 650mm	800mm
	> 650mm	1100mm
> 1400mm	--	1400mm

6. For details of aluminium channel and galvanized mild steel brackets, refer to HyD Standard Drawing No. H2211.
7. The position of two M10 stainless steel bolt heads inserted into each aluminium channel shall be adjusted along the channel to ensure symmetrical position of the street name plate on the supporting frame before tightening.
8. Nominal length of M10 stainless steel bolt shall be 35mm at aluminium channel, 100mm at post of external diameter not exceeding 65mm, and 130mm at post of external diameter exceeding 65mm.
9. Two numbers of blind riverts shall be fixed onto the top flange of the aluminium channel on the outward side of the 2 outermost bolt heads.

REF.	REVISION	SIGNATURE	DATE
B	Note 5 updated.		Sep 07
A	Fixing details revised.		Oct 04
	New issue		Mar 04

FIXING OF DOUBLE STREET NAME PLATES WITH BUILDING NUMBERS ON EXISTING G.I. PIPE SUPPORT

HIGHWAYS DEPARTMENT

REFERENCE	DRAWING No.	CAD
SCALE	H 4119B	
NOT TO SCALE		