

**Notes:**

1. Dimensions are in millimetres.
2. Steel railing to be complying with grade 43 B.S. 4360.
3. Welds are to be sound and continuous avoiding locked-in slag.
4. Welding slags are to be removed immediately after welding
5. Railings, nuts, bolts and washers are to be hot dip galvanized to BS EN ISO 1461:1999.
6. Standard railings to be installed to match the height of existing railings.
7. Where the concrete footing is located in block paved footpath, the footing should be lowered to allow for the paving blocks and the sand course.

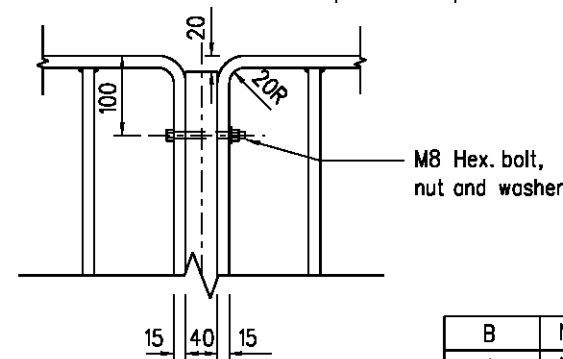

**DETAIL 'Z'**

Scale 1:10

B	Note 5 updated		Sep 07
A	Note 7 added		Nov 99
	New Issue		Nov 98
REF.	REVISION	SIGNATURE	DATE

**TYPE 3 RAILINGS WITHOUT TOP RAIL**

**HIGHWAYS DEPARTMENT**

REFERENCE

DRAWING No.

CAD

SCALE

1:20

**H 4116B**